

GROUP G

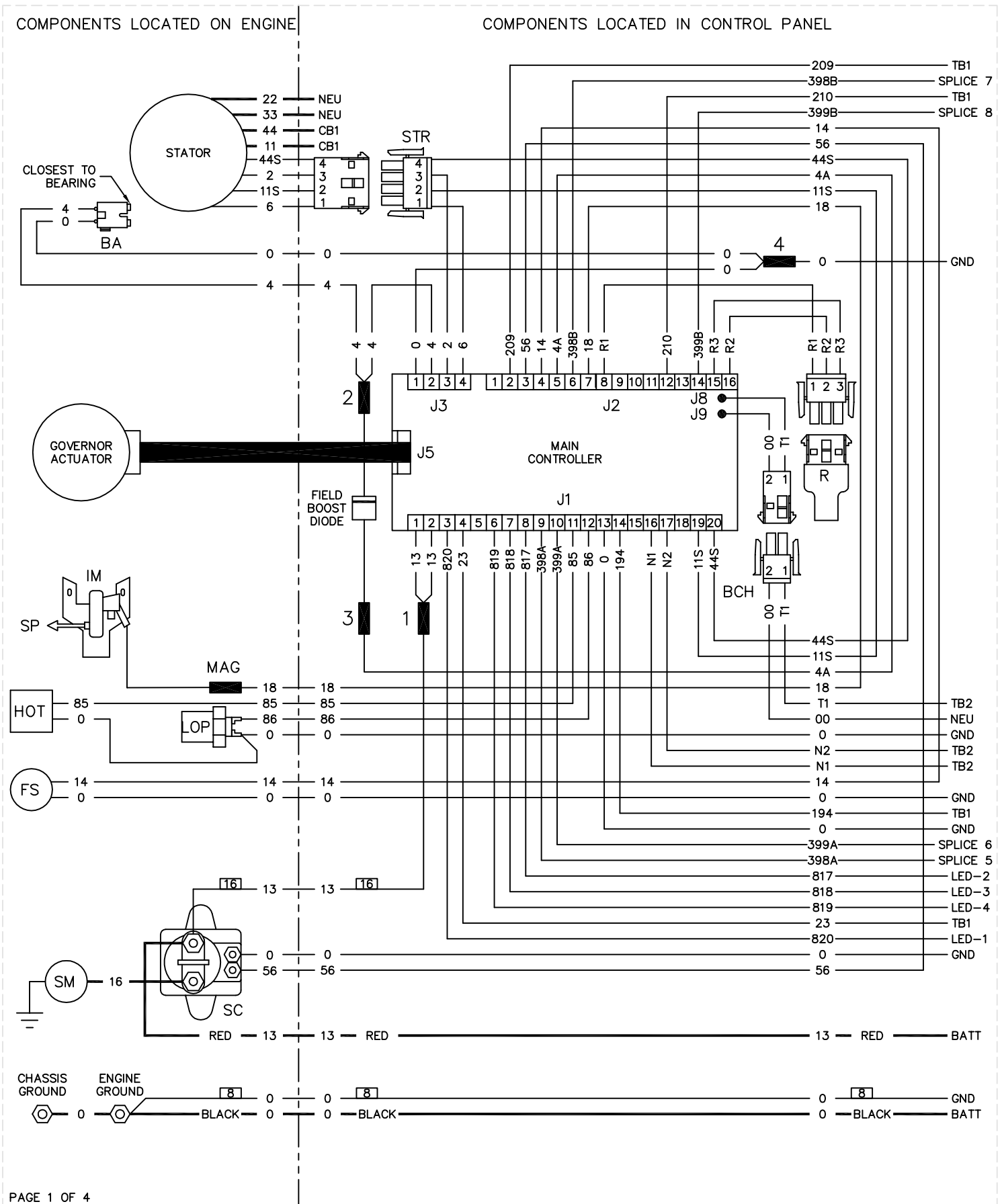

COMPONENTS LOCATED IN CUSTOMER CONNECTION AREA

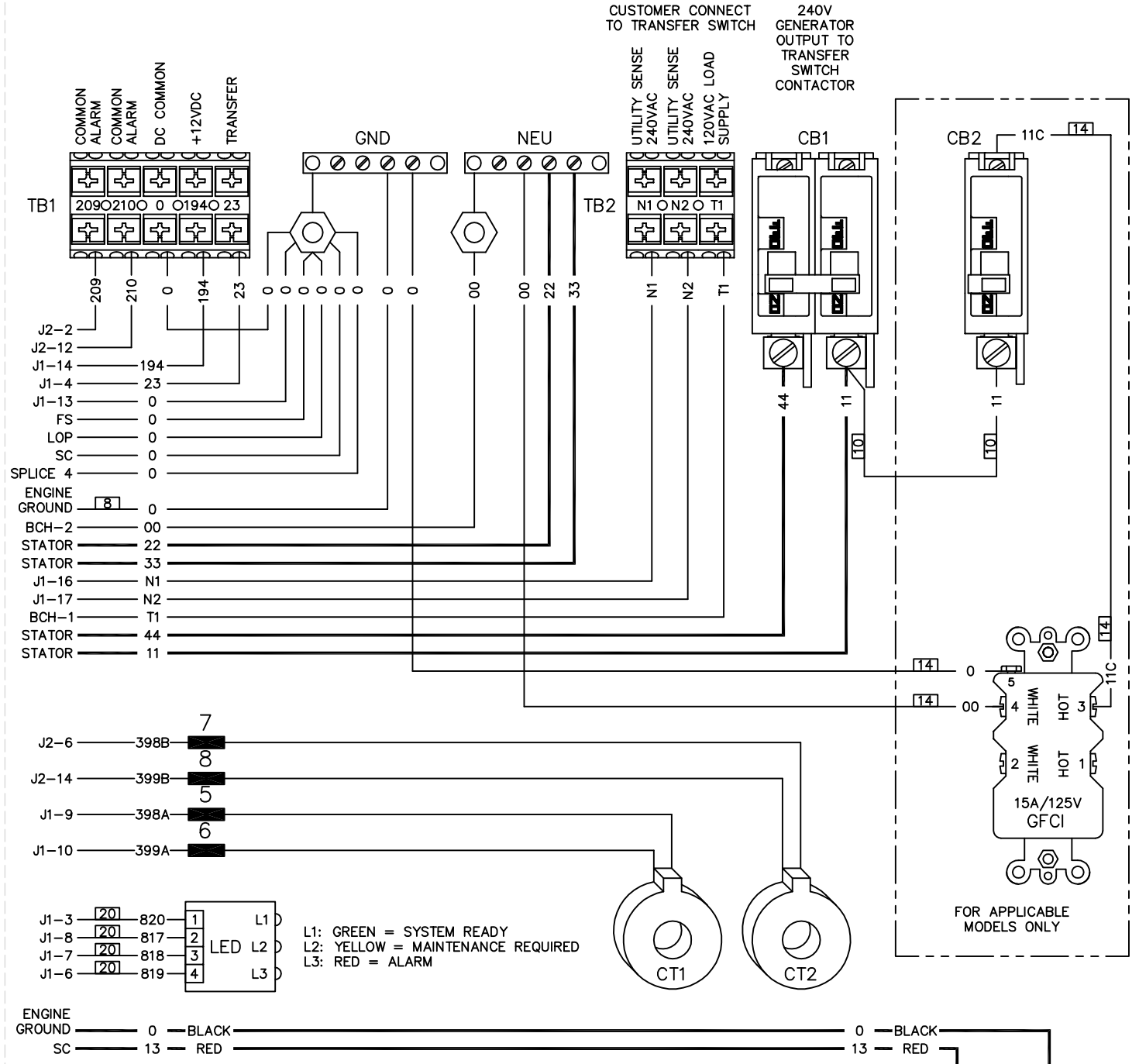

L1: GREEN = SYSTEM READY
L2: YELLOW = MAINTENANCE REQUIRED
L3: RED = ALARM

- LEGEND**
- | | |
|---------------------------------------|------------------------|
| BA - BRUSH ASSEMBLY | NEU - NEUTRAL |
| BATT - BATTERY | R - RESISTOR |
| BCH - BATTERY CHARGER | SC - STARTER CONTACTOR |
| CB1 - CIRCUIT BREAKER (MAIN OUTPUT) | SM - STARTER MOTOR |
| CB2 - CIRCUIT BREAKER (GFCI) | SP - SPARK PLUG |
| CT - CURRENT TRANSFORMER | STR - STATOR |
| FS - FUEL SOLENOID | TB_ - TERMINAL BLOCKS |
| GFCI - GROUND FAULT CIRCUIT INTERRUPT | |
| GND - GROUND | |
| HOT - HIGH OIL TEMPERATURE SWITCH | |
| IM - IGNITION MODULE | |
| LED - LED BOARD | |
| LOP - LOW OIL PRESSURE SWITCH | |
| MAG - MAGNETO | |

NOTE: ALL WIRES 18 AWG 300V UL LISTED UNLESS SHOWN OTHERWISE.

AWG SIZE

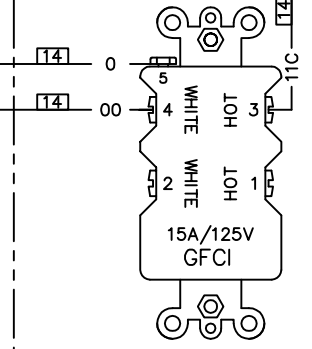
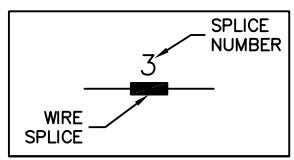

FOR APPLICABLE MODELS ONLY

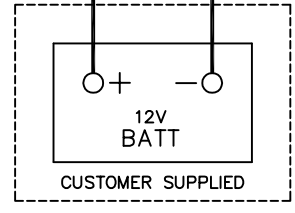

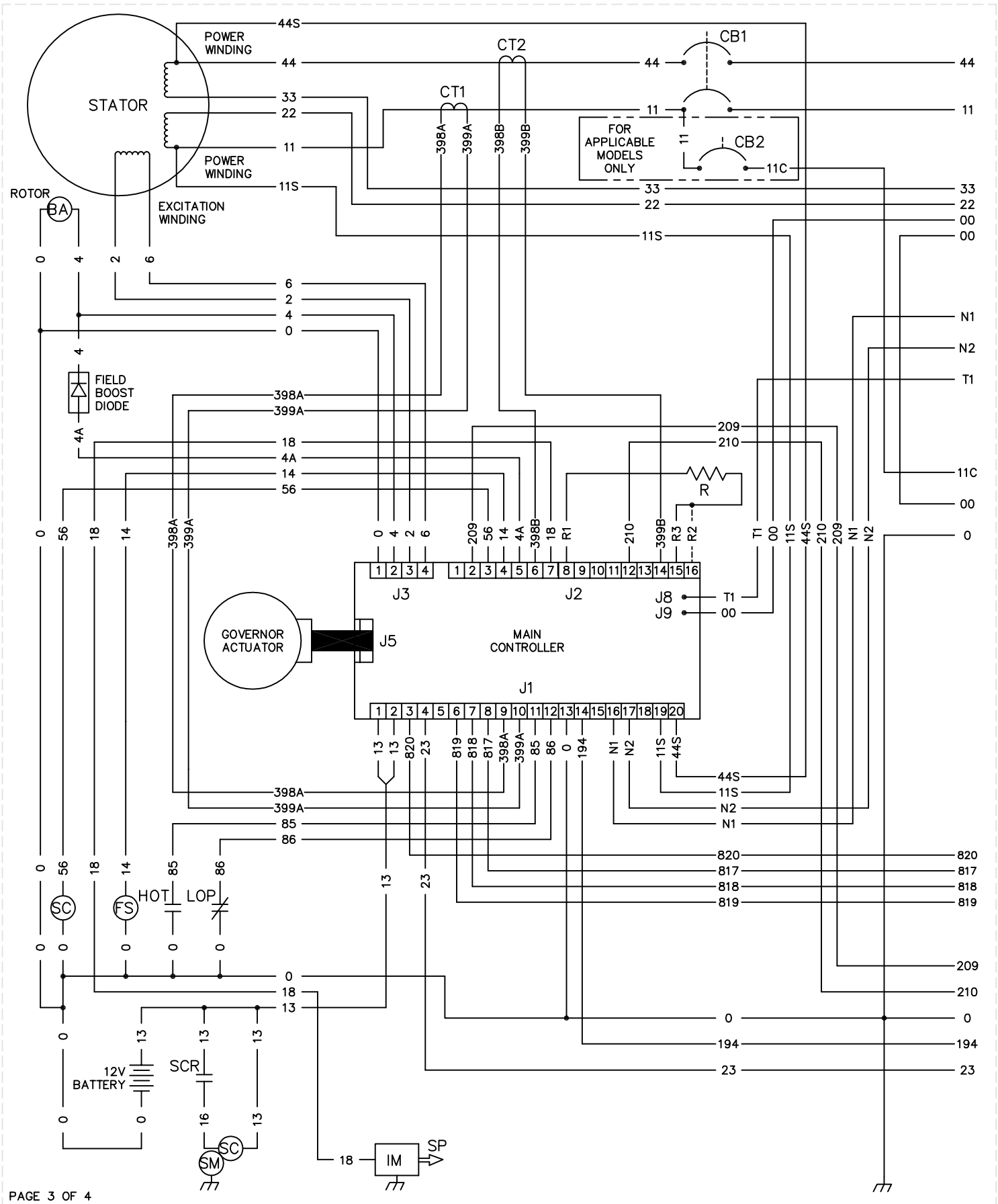

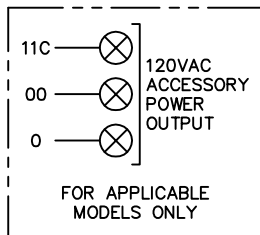
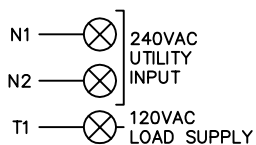
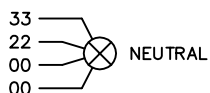
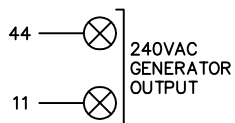

L1: GREEN = SYSTEM READY
L2: YELLOW = MAINTENANCE REQUIRED
L3: RED = ALARM

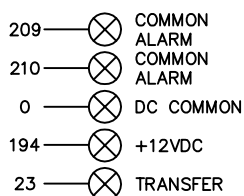
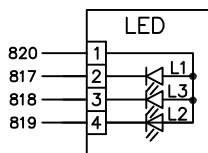

LEGEND

BA - BRUSH ASSEMBLY	LED - LED BOARD
CB1 - CIRCUIT BREAKER (MAIN OUTPUT)	LOP - LOW OIL PRESSURE SWITCH
CB2 - CIRCUIT BREAKER (ACCESSORY POWER)	R - RESISTOR
CT_ - CURRENT TRANSFORMER	SC - STARTER CONTACTOR
FS - FUEL SOLENOID	SCR - STARTER CONTROL RELAY
HOT - HIGH OIL TEMPERATURE SWITCH	SM - STARTER MOTOR
IM_ - IGNITION MODULE	SP_ - SPARK PLUG